

Research Article	Pak-Euro Journal of Medical and Life Sciences	
DOI: 10.31580/pjmls.v8i3.3414	Copyright © All rights are reserved by Corresponding Author	
Vol. 8 No. 3, 2025: pp. 673-682		
www.readersinsight.net/pjmls	Revised: September 09, 2025	Accepted: September 29, 2025
Submission: July 27, 2025	Published Online: September 30, 2025	

## ASSESSMENT OF GENETIC VARIABILITY THROUGH CORRELATION AND PATH ANALYSIS IN BLACKGRAM (*VIGNA MUNGO* L.)

Muhammad Usman<sup>1</sup>, Muhammad Azeem Asad<sup>2</sup>, Muhammad Tariq Mahmood<sup>1\*</sup>, Rubina Nawaz<sup>3</sup>, Hafiz Khalid Zubair<sup>1</sup>, Muaeen Khan<sup>4</sup>, Azmat Ullah<sup>5</sup>, Muhammad Akhtar<sup>6</sup>, Muhammad Ali<sup>5</sup>, Babur Atta<sup>7</sup>



<sup>1</sup>Gram Breeding Research Sub-Station, Kallurkot (Bhakkar), Pakistan

<sup>2</sup>Nuclear Institute for Agriculture & Biology (NIAB), Faisalabad, Pakistan

<sup>3</sup>Pulses Research Institute, Ayub Agriculture Research Institute (AARI), Faisalabad, Pakistan

<sup>4</sup>Agriculture Extension, Adaptive Research Farm, Balochistan, Pakistan

<sup>5</sup>Department of Plant Breeding and Genetics, University of Agriculture, Faisalabad, Pakistan

<sup>6</sup>Department of Plant Breeding and Genetics, Gomal University, Dera Ismail Khan, Pakistan

<sup>7</sup>Department of Plant Breeding and Genetics, Ghazi University, Dera Ghazi Khan, Pakistan

\*Correspondence author: Muhammad Tariq Mahmood. E. mail: [taqaisrani@gmail.com](mailto:taqaisrani@gmail.com)

### Abstract

Blackgram (*Vigna mungo* L.) is a highly valuable legume crop cultivated across Southeast Asia and in the temperate regions of the USA, Canada, and Australia. Commonly known as mashbean, it is a nutritionally rich crop containing high levels of protein, essential minerals, vitamins, and amino acids. However, genetic drift, selection during domestication, and natural mutations have resulted in a narrow genetic base among the available blackgram cultivars. Therefore, the exploration of naturally occurring genetic variability is essential for breeders to enhance the genetic potential of existing cultivars. Despite several efforts, limited progress has been made in identifying and utilizing this variability in blackgram improvement programs.

In the present study, fourteen genotypes of blackgram were evaluated using a Randomized Complete Block Design (RCBD) with three replications. Various morphological and yield-related traits were recorded. Analysis of variance (ANOVA) revealed significant differences among the studied traits, indicating the presence of sufficient genetic variability among the genotypes. Phenotypic correlation analysis showed significant and positive correlations between seed yield and all studied traits, except for 1000-seed weight, which exhibited a non-significant association. Similarly, genotypic correlation analysis indicated a positive and significant relationship between seed yield and most traits, except for a positive but non-significant correlation with 1000-seed weight.

Path coefficient analysis revealed that plant height, number of clusters per plant, number of seeds per pod, 1000-seed weight, and harvest index had significant and direct positive effects on seed yield. In contrast, traits such as 50% flowering, number of branches per plant, number of pods per cluster, and biomass exhibited direct but non-significant effects on yield. The residual effect value was found to be 0.051, indicating that the characters included in this study collectively contributed 94.9% of the total variation in seed yield per plant.

**Keywords:** Analysis of variance, Blackgram, Correlation, Genetic variability, Path analysis, Seed yield

## INTRODUCTION

Leguminosae, also known as Fabaceae or the pea family, is the largest family in the Plantae kingdom, comprising 480 genera and 12,000 species (1). *Vigna mungo* L., commonly known as Blackgram, Urdbean, Urd, and Mash bean, is an annual, self-pollinating legume cultivated in tropical and subtropical regions (2). Blackgram is a diploid species with a chromosome count of  $2n=2x=22$  and a genome size of approximately 0.57 grams per pico coulomb (g/PC), consisting of 574 million base pairs (3). It can be grown in various soil types, including sandy soil, red lateritic, and black cotton, with well-drained sandy loam and a pH range of 6.2-7.2 being optimal for its growth (4).

Blackgram originated primarily from India, where it accounts for 70% of global production (5). Recently, Blackgram cultivation has expanded to countries such as Pakistan, Sri Lanka, Myanmar, Bangladesh, Thailand, the Philippines, and Indonesia (6). According to the Pakistan Economic Survey,



blackgram production in 2023 was 4.2 thousand metric tons over an area of 7 thousand hectares. However, in 2024, production increased by 31.9%, resulting in a yield of 5.6 thousand metric tons over 7 thousand hectares.

Genetic variability is important component for the development of new genotypes, and it ensures survival of species in nature. Variability among genotypes provides a proper objective to breeder to study the specific desired traits in experiments i.e. erect and large height for mechanical harvesting, yield potential, climate resilience, diseases and insects' resistance (7). Effective techniques of breeding can be established by understanding how certain traits are inherited using genetic factors like variance components, phenotypic and genotypic coefficient of variability, heritability and genetic gain. Understanding of genetic variability in yield and yield related traits is necessary for crop improvement specifically in blackgram (8).

Several factors affect pulse productivity, such as shifting rainfall patterns, temperature fluctuations, and water scarcity during vital developmental stages (9). Currently, blackgram cultivars exhibit low yield potential (10). Genetic variability is crucial for enhancing yields and other polygenic traits (11) but the lack of genetic variability within blackgram is a significant handicap for its improvement. There are no idealized, high-yield varieties for various cropping systems (12). Due to low yields, some farmers have abandoned blackgram cultivation, switching to other crops, causing Pakistan to struggle to meet local demand. Genetic variability studies are essential in plant breeding to establish genetically divergent genotypes, which can be identified through genetic divergence analysis for further studies (13). Understanding genetic diversity is crucial for crop improvement. Analyses such as phenotypic coefficient of variation, genotypic coefficient of variation, genetic advance, and heritability help exploit genetically divergent genotypes for future breeding programs (14).

Heritability is a crucial parameter for predicting genetic advancement under various levels of selection, especially for assessing trait expressivity under different agro-climatic conditions. Combined estimation of genetic advance and heritability is more valid for selection (15). Since seed yield is a complex trait associated with various components, studying the correlations among these components is vital (16). Path analysis simplifies the identification of yield components and factors influencing yield. To determine the traits contributing to seed yield in pulses, the study began by measuring the genetic variability, associations, and path coefficient assessments of commercially relevant plant properties. Previous research has assessed the variability in blackgram yield and its component features (17).

Decline in blackgram production per unit area is attributed to vulnerability of genotypes to diverse environments, lack of high yielding and stable cultivars. Therefore, it is crucial for pulse breeders to develop high yielding and climate resilient cultivars of blackgram. Crop improvement can be determined by the degree of genetic diversity and the extent to which traits are transmitted from one generation to the next (18). Blackgram genotypes with high-yield potential can be developed by making the selection criteria that are supported by genetic variability, heritability, and genetic improvement (19).

There is lack of genetic variability in blackgram and most of existing germplasm have narrow genetic base. So, it does not perform better in diverse environments. Through this experiment we tried to analyze genotypes of blackgram which could perform better in different environments.

The main objective of this study is to identify genotypes with high-yield potential by assessing genetic diversity for future breeding programs.

## METHODOLOGY

The present study evaluates the genetic divergence in fourteen lines of blackgram. The germplasm was collected from the Plant Genetic Research Institute (PGRI). The experiment was conducted at the Nuclear Institute for Agriculture and Biology (NIAB) Faisalabad, Pakistan in the plant breeding and genetics experimental area during spring 2023.

Before sowing, the experimental block was irrigated three times, with the third irrigation including Biflex (a termiticide). The land was ploughed, and pendimethalin 2500 ml per hectare was sprayed to prevent the re-emergence of weeds. The soil was carefully leveled using a rotavator, and sowing was



performed using a dibbler at a depth of 2.5-3.0 cm from the soil surface. The genotypes were planted in an open field with three replications under Randomized Complete Block Design (RCBD). 40 seeds of each genotype were grown per replication. The plot size for the experiment was 10.5 ft × 56ft (588.5 ft<sup>2</sup>). Plant-to-plant and row-to-row distances were maintained at 6 inches and 12 inches, respectively. Three random plants were chosen from each genotype per replication for data recording. Thirteen morpho-yield traits *viz.*, plant height (cm), days to 50% flowering, number of branches per plant, number of clusters per plant, number of pods per cluster, number of pods per plant, pod length (cm), pod width (cm), number of seeds per pod, plant biomass (g), 1000 seeds weight (g), seed yield (g) and harvest index (%) were recorded. The analysis of variance (ANOVA) was carried out for the significance of variance among the genotypes by using the mean values of recorded data. Tukey HSD test was applied to check significant mean comparison among the genotypes. By using the formulas (20), the different genetic parameters, including GCV, PCV, heritability, and GAM, were determined. Phenotypic correlation, genotypic correlation and path analysis were applied to check the inter relation of traits to contribute to yield and direct and indirect significant effect of these traits on yield. Correlation and path analysis of these traits were found by using the R software and their diagrams were also made on R software.

## RESULTS AND DISCUSSION

Thirteen different traits of 14 genotypes of black gram were subjected to analysis of variance shown in Table I, showed highly significant results for traits at P value 0.01 except No. of clusters per plant showed significant at P value 0.05. While number of pods per cluster, pod width, thousand seeds weight showed non-significant difference among the genotypes of black gram. Similar results were observed in different studies (21-23).

**Table I.** Analysis of variance for yield related traits in blackgram

Characters	Replications	Treatments	Error
Degree of freedom	2	13	26
Flowering 50%	0.38	28.35**	0.79
Plant height	2.42	77.15**	5.83
No. of Branches per plant	3.12	7.15**	0.82
No. of clusters per plant	19.65	40.99*	9.52
No. of pods per cluster	0.35	0.26 <sup>NS</sup>	0.13
No. of pods per plant	151.16	151.23**	35.54
Pod length	2.42	77.15**	5.83
Pod width	0.0002	0.00141 <sup>NS</sup>	0.0006
Biomass	59.80	124.85**	26.93
No. of seeds per pod	0.03	0.48**	0.07
Seed yield	15.92	26.26**	3.62
Thousand seeds weight	40.48	25.57 <sup>NS</sup>	16.12
Harvest index (%)	16.63	17.37**	16.42

\*\* Highly significant at P=0.01, \* Significant at P=0.05, NS = non-significant

The estimates of genotypic variance, phenotypic variance, genotypic coefficient of variation, phenotypic coefficient of variation, heritability, genetic advance, and genetic advance per mean for different parameters are represented in Table II. Highest estimates of genotypic and phenotypic variation recorded for the trait biomass 65.97 and 92.91 respectively. Highest estimates genotypic coefficient of variation was observed of number of branches per plant 19.39 while phenotypic coefficient of variation 23.36 of No. of clusters per plant similar findings were recorded by Shoba 2018 (24). Highest heritability was recorded 92% of days to flowering 50% similar to the findings of Partap *et al.*, 2019 (25). Highest genetic advance was 9.00 observed for plant height. These similar results were also found in another study (26). Therefore, these traits can be used for the selection of plants to develop new varieties.

**Table II.** Estimates of genetic parameters of yield related traits in blackgram

Characters	Vg	Vp	GCV	PCV	Heritability (%)	GA	GAM
Days to flowering 50%	9.19	9.98	5.74	4.53	92	5.99	11.34
Plant height	23.77	29.61	9.23	10.30	80	9.00	17.04
No. of Branches per plant	2.11	2.93	19.39	22.85	72	2.54	33.90
No. of clusters per plant	10.49	20.01	16.91	23.36	52	4.83	25.23
No. of pods per cluster	0.04	0.18	6.77	13.52	25	0.22	6.97
No. of pods per plant	38.56	74.10	15.82	21.93	52	9.23	23.51
Pod length	23.77	29.61	18.01	20.10	80	9.00	33.24
Pod width	0.000256	0.0008967	2.81	5.26	28.5	0.01761	3.09345
Biomass	65.97	92.91	26.80	31.81	71	14.10	46.53
No. of seeds per pod	0.14	0.21	6.05	7.38	67	0.63	10.22
Seed yield	7.12	10.74	30.20	50.66	66	4.48	41.25
Thousand seeds weight	3.150	19.274	3.241	8.016	16.3	1.478	2.699
Harvest index (%)	12.71	29.13	9.84	14.90	44	4.85	13.38

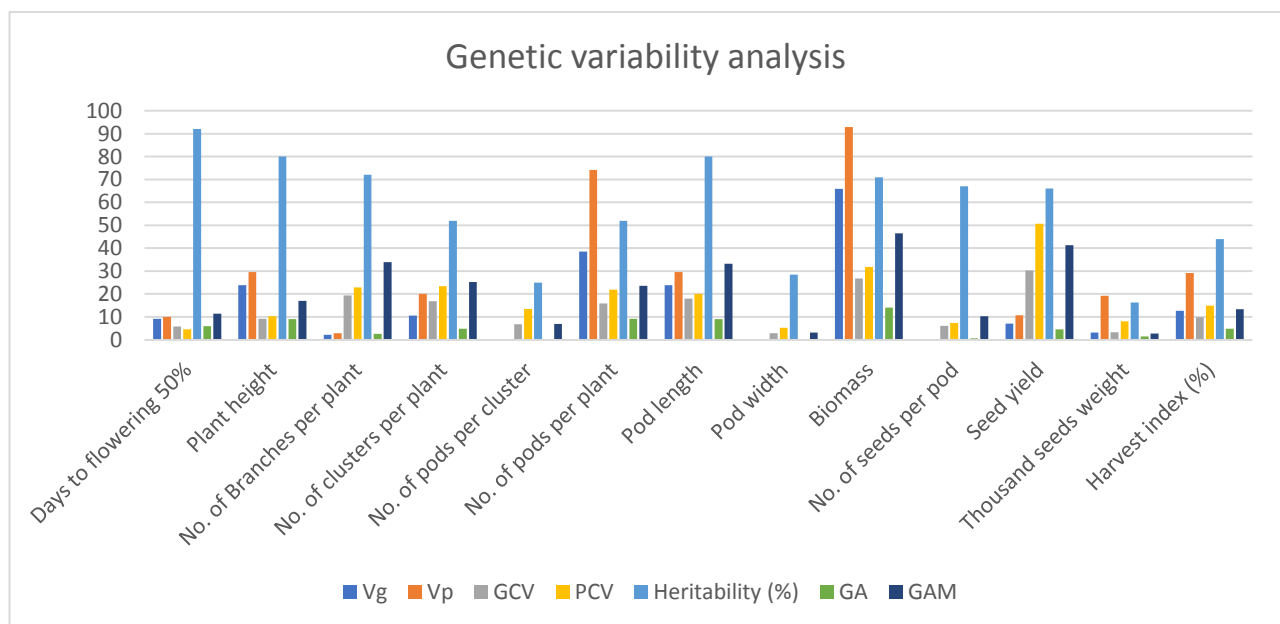
**Fig. 1.** Estimates of genetic parameters of yield related traits in black gram

## CORRELATION

Correlation provides information about the phenotypic and genotypic importance of the traits. The correlation between all possible combinations among the characters was estimated at genotypic and phenotypic levels through R software and is presented in Tables III and IV respectively also in Figures 2 and 3 made by R software.

Seed yield showed the positive and highly significant genotypic correlation with days to 50% flowering, plant height, number of branches per plant, number of clusters per plant, pods per plant, pod length, pod width, biomass and harvest index which were similar findings with (14, 27- 29). Therefore, to increase the number of seeds produced per plant, these traits would be used in direct selection. While seed yield with 1000 seeds weight showed positive and non-significant which was similar to the results of Sravani *et al.*, 2021(30). Seeds per pod showed negative and non-significant correlation with pods per cluster, similar findings were observed by Praneetha *et al.*, 2025 (19). Although both the genotypic and phenotypic correlations were leading in the same direction, the genotypic correlation coefficients were higher in magnitude than the equivalent phenotypic correlation coefficient. The environment's impact on plant phenotypes may be the cause of this low level of phenotypic correlation.

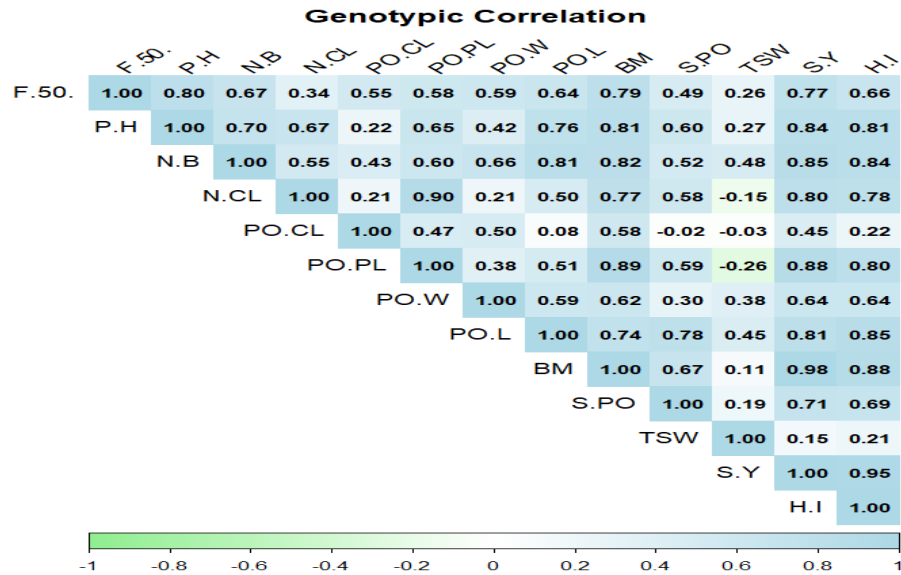

Fig. 2. Genotypic correlation analysis of yield related traits

Table III. Genotypic correlation analysis of yield related traits

GC	F.50.	P.H	N.B	N.C.L	P.O.C.L	P.O.P.L	P.O.L	P.O.W	B.M	S.P.O	S.Y	T.S.W	H.I
F.50.	1.00	0.80**	0.67**	0.34	0.55**	0.58**	0.64**	0.59**	0.79**	0.49*	0.77**	0.26	0.66**
P.H		1.00	0.70**	0.67**	0.22	0.65**	0.76**	0.42*	0.81**	0.60**	0.84**	0.27	0.81**
N.B			1.00	0.55**	0.43*	0.60**	0.81**	0.66**	0.82**	0.52**	0.85**	0.48*	0.84**
N.C.L				1.00	0.21	0.90**	0.50**	0.21	0.77**	0.58**	0.80**	-0.15	0.78**
P.O.C.L					1.00	0.47*	0.08	0.50**	0.58**	-0.02	0.45*	-0.03	0.22
P.O.P.L						1.00	0.51**	0.38*	0.89**	0.59**	0.88**	-0.26	0.80**
P.O.L							1.00	0.59**	0.74**	0.78**	0.81**	0.45*	0.86**
P.O.W								1.00	0.62**	0.30	0.64**	0.38	0.64**
B.M									1.00	0.67**	0.99**	0.11	0.88**
S.P.O										1.00	0.71**	0.19	0.69**
S.Y											1.00	0.15	0.95**
T.S.W												1.00	0.22
H.I.													1.00

\* Significant at P = 0.05 and \*\* significant at P = 0.01

GC= Genotypic correlation, F.50.= Days to 50% flowering, P.H= Plant Height, N.B= Number of branches per plant, N.C= Number of clusters per plant, P.O.C.L= Pods per cluster, P.O.P.L= Pods per plant, P.O.L= Pod length, P.O.W= Pod width, B.M= Biomass, S.P.O= Seeds per pod, S.Y= Seed yield, T.S.W= seed weight, H.I= Harvest Index (%)

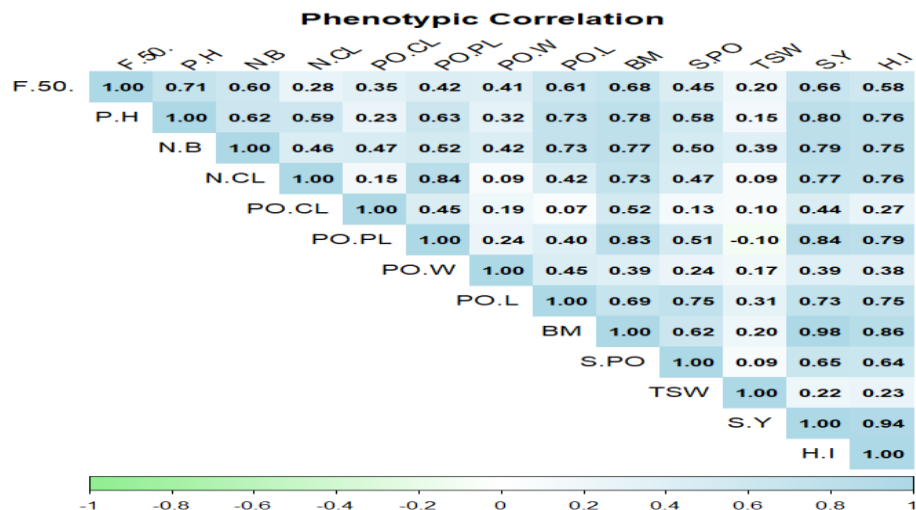

Fig 3. Phenotypic correlation analysis of yield related traits

**Table IV.** Phenotypic correlation analysis of yield related traits

PC	F.50.	P.H	N.B	N.CL	PO.CL	PO.PL	PO.L	PO.W	BM	S.PO	S.Y	TSW	H.I
F.50.	1.00	0.71**	0.60**	0.28	0.35	0.42*	0.61**	0.41	0.68**	0.45	0.66**	0.20	0.58**
P.H		1.00	0.62**	0.59**	0.23	0.63**	0.73**	0.32	0.78**	0.59**	0.81**	0.15	0.77**
N.B			1.00	0.46*	0.47*	0.52**	0.73**	0.42*	0.78**	0.51**	0.79**	0.39*	0.75**
N.CL				1.00	0.15	0.84**	0.43*	0.09	0.73**	0.47*	0.77**	0.09	0.76**
PO.CL					1.00	0.45*	0.07	0.19	0.53**	0.13	0.44*	0.10	0.27
PO.PL						1.00	0.40*	0.24	0.83**	0.51**	0.84**	-0.10	0.79**
PO.L							1.00	0.45*	0.69**	0.75**	0.73**	0.31	0.75**
PO.W								1.00	0.39	0.24	0.39*	0.17	0.38
BM									1.00	0.62**	0.98**	0.20	0.86**
S.PO										1.00	0.65**	0.09	0.64**
S.Y											1.00	0.22	0.94**
TSW												1.00	0.23
H.I.													1.00

\* Significant at P = 0.05 and \*\* significant at P = 0.01

## PATH ANALYSIS

Seed yield is the product of interaction involving several factor components which may also be interrelated among them. Path coefficient is a standardized regression coefficient technique that assesses the influence of different components upon final seed yield per plant directly or indirectly, by partitioning the genetic correlation. This technique was originally proposed by Wright 1921 (31) and used by Dewey & Lu 1959 (32) in plant breeding experiments. Such information is useful in predicting correlated responses of different characters in directional selection. Keeping seed yield per plant in blackgram as a resultant variable the results achieved in Path coefficient studied on plant performance traits like days to 50% flowering, plant height, number of branches, number of clusters per plant, number of pods per cluster, number of pods per plant, pod length, pod width, number of seeds per pod, number of seeds per plant, biomass, and harvest index.

**Table V.** Genotypic path analysis of yield related traits with seed yield

	F.50.	P.H	N.B	N.CL	PO.CL	PO.PL	PO.L	PO.W	S.PO	TSW	BM	H.I	S.Y
F.50.	0.031	0.062	0.035	0.032	0.042	0.019	-0.059	0.012	0.067	0.058	-0.043	0.704	0.007
PH	0.026	0.073	0.036	0.060	0.013	0.019	-0.070	0.008	0.080	0.075	-0.044	0.839	0.502**
N.B	0.022	0.054	0.049	0.053	0.025	0.019	-0.077	0.014	0.068	0.117	-0.049	0.905	0.008
N.CL	0.012	0.053	0.032	0.082	0.020	0.027	-0.049	0.006	0.087	-0.073	-0.039	0.814	0.62**
PO.CL	0.024	0.017	0.023	0.031	0.054	0.017	-0.009	0.016	-0.025	-0.020	-0.028	0.244	0.005
PO.PL	0.021	0.049	0.034	0.079	0.032	0.028	-0.052	0.009	0.084	-0.058	-0.044	0.817	0.027
PO.L	0.020	0.057	0.042	0.045	0.005	0.017	-0.089	0.012	0.104	0.112	-0.044	0.917	0.016
PO.W	0.025	0.040	0.048	0.032	0.060	0.017	-0.070	0.015	0.050	0.144	-0.050	0.968	0.015
S.PO	0.016	0.045	0.026	0.055	-0.010	0.018	-0.072	0.006	0.129	0.063	-0.036	0.904	0.504**
TSW	0.012	0.036	0.037	-0.039	-0.007	-0.011	-0.065	0.014	0.052	0.155	-0.018	0.722	0.752**
BM	0.026	0.062	0.047	0.062	0.029	0.024	-0.077	0.014	0.091	0.054	-0.052	0.959	0.019
H.I.	-0.008	-0.012	-0.025	0.016	-0.019	0.002	0.034	-0.012	0.010	-0.132	0.019	0.300	0.451*
Resid ue	0.051												

From the table V, path analysis showed direct positive effect of days to 50% flowering, plant height, number of branches per plant, number of clusters per plant, pods per cluster, pods per plant, pod length, pod width, seeds per pod, biomass and harvest index with seed yield which were similar to the results of the (1, 33, 34). In this table 0.451 value of harvest index shows the strong positive effect on seed yield similar findings found by (35) and (36). 0.752 value shows the very strong positive effect of thousand seed weight on seed yield similar results found by (18). These traits are effective for the selection of high yielding plants as they revealed direct positive effects on seed yield along with positive and significant correlation.

In Fig. 4 it is shown that seed yield has positive and direct effects with all traits especially with biomass, thousand seed weight and harvest index so these traits can be used for the selection of high yielding genotypes in further experiments (37). Strong positive and direct effect of number of clusters on seed yield found 0.62 similar results found by Sindhu *et al.*, 2023 (38).

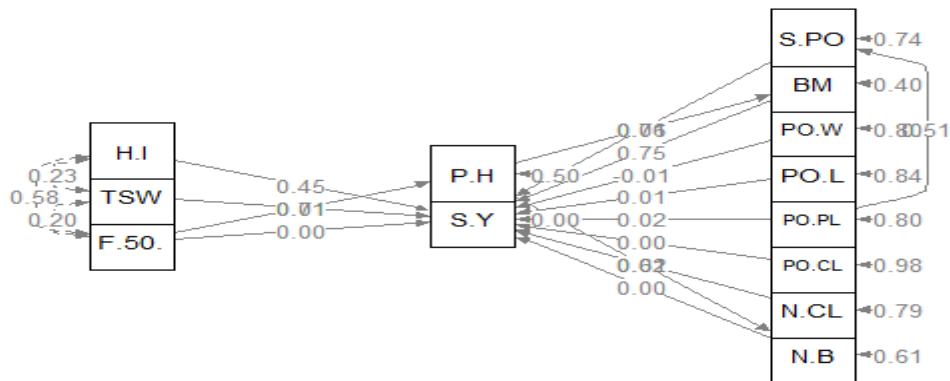

Fig. 4. Path analysis diagram for seed yield

## CONCLUSION

Through present study analyzed traits presented enough amount of genetic variability. Biomass showed high genotypic and phenotypic variation. Days to 50% flowering showed high heritability. All the traits studied showed positive and significant correlation with seed yield except 1000 seed weight which was positive and non-significant. Seed yield $\text{plant}^{-1}$  exhibited highly significant correlation with seed yield among all traits. Path analysis of all the traits showed positive and significant effect on seed yield except days to 50% flowering and number of branches. The study explains the existence of sufficient diversity in performance of different traits of studied genotypes of blackgram. Therefore, these diverse traits may further be utilized for black gram genetic improvement program.

### Authors' contribution:

MU conducted the research work and did write up, MAA supervised the research; MTM statistical analysis and correspondence, RN & HKZ collected data, MK & AU interpreted results, MA & BA data analysis, checked plagiarism and grammar correction.

### References:

1. Khanvilkar O, Shinde S, Patil A, Kute N. Path coefficient analysis for important yield components in black gram [Vigna mungo (L.) Hepper]. Legum Res. 2022;LR-4719.
2. Tank HK, Dhedhi KK, Joshi HJ, Vachhani JH, Kachhadia VH. Genetic variability and heritability studies in blackgram (Vigna mungo (L.) Hepper). Int J Chem Stud. 2018;6(6):642-6.
3. Gayacharan, Rana JC, Yadav SK, Kaur M, Tripathi K, Sharma S, et al. Understanding genetic diversity in blackgram [Vigna mungo (L.) Hepper] collections of Indian National Genebank. Genet Resour Crop Evol. 2022;69:1-17.
4. Dheeraj AG, Salimath PM, Kajjidoni ST, Patil MS. Mean Performance and Correlation Coefficient Analysis for Seed Yield and Related Traits in Blackgram Parents and Crosses. Int J Curr Microbiol Appl Sci. 2020;9(7):1972-7.
5. Shoba D, Jebaraj S, Anbumalarmathi J. Genetic Variability and Association Studies on Yield and Yield Attributing Traits in Blackgram (Vigna mungo L. Hepper). Madras Agric J. 2024;17(4):901-7.
6. Anbazhagan S, Palaniyappan JHH. Intergenerational relationship and Multi-trait Genotype-Ideotype Distance Indexing (MGIDI) in inter-varietal cross derivatives of black gram [Vigna mungo (L.) Hepper]. J Appl Nat Sci. 2025;12(1):1-5.
7. Mahmood MT, Akhtar LH, Sadiq MS, Sarwar G. Genetic variability assessment among elite chickpea (Cicer arietinum) genotypes under water deficit conditions. J Agric Sci. 2024;7(1):31-8.
8. Wagh A, Patil RS, Khaire AB, Kute NS. Genetic variability, heritability and genetic advance in black gram (Vigna mungo L.). J Pharmacogn Phytochem. 2019;8(1S):799-801.

9. Bordoloi D, Sarma A, Sarma D. Character Interrelationship and Principle Component Analysis of Some Black Gram (*Vigna mungo* L. Hepper) Genotypes under Moisture Stress Deficit Environment. *Int J Environ Clim Change*. 2022;12(10):1190-204.
10. Ragul S, Jebaraj S, Anbumalarmathi J. Genetic Analysis on Yield and Yield Components Traits in the Segregating Populations of Blackgram [*Vigna mungo* (L.) Hepper]. *Madras Agric J*. 2022;108(10-12):1-7.
11. Narayanan M, Jebaraj S, Anbumalarmathi J. Genetic variability, correlation, path coefficient analysis for yield and yield components in F4 progenies of KKM 1 × VBN 6 in black gram (*Vigna mungo* L. Hepper). *Pharma Innov J*. 2021;10(11):1248-53.
12. Varaprasad K, Suresh J, Kumar SS, Reddy PS. Genetic Variability, Correlation and Path Coefficient Analysis for Yield and Yield Components in Blackgram (*Vigna mungo* (L.) Hepper): Experimental Investigation. *Int J Plant Soil Sci*. 2022;34(23):519-31.
13. Kumar BV, Reddy DM, Sudhakar P, Eswari KB. Principal Component Analysis and Traits Association in Blackgram (*Vigna mungo* (L.) Hepper). *Int J Plant Soil Sci*. 2022;34(23):37-48.
14. Gantait A, Prajapati DK, Maxton A. Assessment of genetic variability, correlation and path co-efficient studies on yield and its component in Mungbean (*Vigna radiata* L. wilczek). *Plant Arch*. 2025;25(2):1634-40.
15. Teja MKV, Lal G. Study of genetic variability and character association for yield and yield related traits in f3 generation of blackgram (*Vigna mungo* (L.) Hepper). *Int J Environ Agric Biotechnol*. 2021;6(3):93-9.
16. Hegde PM, Salimath PM, Kumar B, Keerthi C. Assessment of variability for seed yield in back cross derived lines of blackgram (*Vigna mungo* L. hepper). *Plant Arch*. 2025;25(1):3182-5.
17. Mukesh SY, Kumar S, Kumar A, Kumar V. Genetic basis of yield variation in spring mungbean (*Vigna radiata* L.): A correlation and path analysis study. *Environ Conserv J*. 2024;15:1-7.
18. Sai BV, Kumar SS, Reddy PS, Suresh J. Genetic Diversity for Grain Yield and Its Attributed Traits in Blackgram [*Vigna mungo* (L.) Hepper]. *Ecol Environ Conserv*. 2025;37(8):338-47.
19. Praneetha TP, Jebaraj S, Anbumalarmathi J. Study on Genetic Variability and Trait Evaluation in Blackgram (*Vigna mungo* (L.) Hepper) Genotypes. *Madras Agric J*. 2025;47(8):274-84.
20. Johnson HW, Robinson HF, Comstock RE. Estimates of genetic and environmental variability in soybeans. *Agron J*. 1955;47(7):314-8.
21. Kumar BV, Reddy DM, Sudhakar P, Eswari KB. Principal Component Analysis and Traits Association in Blackgram (*Vigna mungo* (L.) Hepper). *Int J Plant Soil Sci*. 2022;34(23):37-48.
22. Prithvi RSP, Lal GM. Studies on genetic variability and character association in f5 generation of blackgram (*Vigna mungo* (L.) hepper). *J Pharmacogn Phytochem*. 2019;8(5):2445-8.
23. Bhanuprasad P, Kumar SS, Reddy PS, Suresh J. Genetic Parameters and Diversity Analysis in Blackgram (*Vigna mungo* L. Hepper) for Seed Yield Characters. *Int J Plant Soil Sci*. 2022;34(24):340-7.
24. Shoba D. Genetic variability and correlation studies in black-gram [*Vigna mungo* (L.) Hepper]. *Environ Ecol*. 2018;9(4):1583-7.
25. Partap B, Kumar S, Rani M, Kumar A. Genetic variability and correlation studies of seed yield and its components in black gram (*Vigna mungo* (L.) Hepper). *J Pharmacogn Phytochem*. 2019;8(3):2035-40.
26. Reddy D, Suresh J, Kumar SS. Genetic parameters and inter-relationship analysis in blackgram [*Vigna mungo* (L.) Hepper]. *Legum Res*. 2011;34(2):149-52.
27. Yadav M, Lal GM, Lavanya GR. Correlation and path analysis in m4 generation of Blackgram [*Vigna mungo* (L.) Hepper]. *J Pharm Innov*. 2023;12(7):2558-63.
28. Mallikarjuna G, Jyothula D, Rao VS. Correlation and Path Coefficient Studies in Blackgram. *Agric Sci Dig*. 2020;40(2):124-8.
29. Radhikaben NP, Bala M. Correlation Studies for Yield and its Components in Black Gram [*Vigna mungo* (L.) Hepper]. *Int J Curr Microbiol Appl Sci*. 2020;9(9):1441-7.
30. Sravani P, Kumar SS, Reddy PS, Suresh J. Studies on inter-relationship and cause effect for yield and its attributes of Black gram (*Vigna mungo* L. Hepper) genotypes. *J Pharm Innov*. 2021;10(11):1745-9.
31. Wright S. Correlation and causation. *J Agric Res*. 1921;20(7):557-85.
32. Dewey DR, Lu KH. A correlation and path-coefficient analysis of components of crested wheatgrass seed production. *Agron J*. 1959;51(9):515-8.
33. Babu JS, Kumar SS, Reddy PS, Suresh J. Correlation and Path Analysis for Yield Components in Blackgram. *Agric Sci Dig*. 2021;41(Special Issue):178-82.
34. Gangadhar L, Kumar SS, Reddy PS, Suresh J. Direct and Indirect Effects of Yield Contributing Characters on Seed Yield in Black Gram (*Vigna mungo* (L.) Hepper). *Biol Forum*. 2022;14(3):2016-27.

35. Ritika RP, Sharma D, Agrawal A. Correlation and path analysis of yield and related traits in urdbean [Vigna mungo (L.) Hepper] genotypes. *Int J Res Anal Rev.* 2024;7(3):246-51.
36. Rathore T, Sharma D, Agrawal A, Singh Y. Character association and path analysis for yield and its attributing traits in Urdbean genotypes and its triple test cross F1 hybrids. *Legum Res.* 2024;30(7):429-36.
37. Reddy KS, Kumar SS, Reddy PS, Suresh J. Studies on Correlation and Path Analysis for Seed Yield and Yield Attributing Characters in Blackgram (Vigna mungo (L.) Hepper). *J Pharm Innov.* 2021;10(11):1750-4.
38. Sindhu N, Salimath PM, Kajjidoni ST, Patil MS. Assessment of genetic variability, character association and path analysis for yield and yield attributes in blackgram (Vigna mungo (L.) hepper). *J Pharm Innov.* 2023;12(7):2564-70.

